

EU-TYPE EXAMINATION CERTIFICATE

Equipment or Protective System Intended for use in Potentially Explosive Atmospheres Directive 2014/34/EU

- EU-Type Examination Certificate Number:** ETL22ATEX0109X **Issue 00**
- Product:** Cable Glands, Blanking Elements/Stopping Plugs, Reducer, Adaptor, Adapter Nipple & Couplings and Breather/drain plugs
- Manufacturer:** Akshar Brass Industries
- Address:** Plot No. 46, 47, 50, 51 Survey No. 238, 245, 246 Naghedi Industrial Area, Jamnagar - 361 006 Gujarat India
- This product and any acceptable variation thereto is specified in the schedule to this certificate and the documents therein referred to.
- Intertek Testing Services NA Ltd., Notified Body number 2903 in accordance with Article 17 of Directive 2014/34/EU of the European Parliament and of the Council dated 26 February 2014, certifies that the product has been found to comply with the Essential Health and Safety Requirements relating to the design and construction of products intended for use in potentially explosive atmospheres given in Annex II of the Directive.
The examination and tests results are recorded in confidential technical evaluation Intertek India Report No. CE-JOB-NDA-22-000031-005 (Intertek UK Certification Report Reference No. G104937979) dated 20th April 2022, Intertek India Report No. CE-JOB-NDA-19-000073-003 (Intertek UK Certification Report Reference No. G103831646) dated 14th June 2019 and Intertek India Report No. CE-JOB-DEL-14-000650-003 to 007 (Intertek UK Certification Report Reference No. G101888827) dated 12th September 2016.
- Compliance with the Essential Health and Safety Requirements has been assured by compliance with EN IEC 60079-0:2018, EN 60079-1:2014, EN IEC 60079-7:2015+A1:2018 and EN 60079-31:2014 except in respect of those requirements referred to within item 14 of the Schedule.
- If the sign "X" is placed after the certificate number, it indicates that the product is subject to the special conditions of use specified in the Schedule to this certificate.
- This EU-Type Examination Certificate relates only to the design and construction of the specified product. Further requirements of the Directive apply to the manufacturing process and supply of this product. These are not covered by this certificate.
- The marking of the product shall include the following:



II 2 G D

Ex db IIC Gb
Ex eb IIC Gb
Ex tb IIIC Db

Certification Officer: _____
M Newman

Date: _____
11th May 2022

SCHEDULE:

EU-Type Examination Certificate Number: ETL22ATEX0109X

11. Description of Equipment or Protective System

Akshar Brass Industries manufacture CABTEK Brand Cable Glands, Blanking Elements/Stopping Plugs, Reducer, Adaptor, Adapter Nipple & Coupling and Breathers/drain plugs are certified for Zone 1, 2, 21 and 22.

Cable Glands are metallic in construction and intended to terminate circular armoured, unarmoured and braided cables and flat Cables (as defined by their type designations) into a threaded entry point within associated Flameproof, Increased safety or dust tight enclosures. Without compromising the explosion protection provided by the enclosures in accordance with relevant codes of practice and suitable for Cold Flow applications.

Cable Glands, Blanking Elements/Stopping Plugs, Breather Plug, Adaptor, Reducer, Adaptor Nipple and Coupling are intended for Indoor and outdoor use in the appropriate Hazardous areas are made from Brass or Stainless Steel SS316L, Cable sealing rubbers are made of Silicone and Substrate rubber made of Nylon providing environmental protection IP66/IP67/IP68 with entry thread of Metric and NPT (Taper threads) for Ex “db” Protection, While Ex “eb” protection having Metric, NPT (Taper Threads), BSP, PG and ET.

Cable Glands can be produced with extended entry thread with 20mm or 25mm length and conduit connection facility in gland as per customer need without changing flame path and cable clamping range.

- E1FW, E1FX and E1FU Double Compression Cable Glands with Universal Armoured Ring are designed for armoured cables
- CWe, CXe / CUe Single Compression Cable Glands with Universal Armoured Ring for armoured cables
- A2F and IP68 Cable Glands designed for non-armoured and braided cables
- PX2K Cable Gland are for armoured cable with Compound Barrier seal
- PXSS2K Cable Gland are for unarmoured cable with Compound Barrier Seal
- A2F-MH Cable Gland for Multi Core cable to terminate individually
- A2F-MHFC, A2F-MHRF, A2F-MHRM Cable Gland for multi core cable to terminate individually with conduit connection
- A2F-FF Cable Gland for Flat/Tracer cable to terminate individually
- A2FFFC, A2FFRF, A2FFRM Cable Gland for Flat/Tracer cable to terminate with conduit connection
- SS2KGP-FF Cable Gland for Flat/Tracer cable with double compression

The Blanking Elements/Stopping Plugs are manufactured with an external male thread along its length with the exception of a Hexagonal (HSP Series) or Allen (Dome) Head (ASP Series) at one end.

Adaptor/Reducer/Nipple/Coupling

- Adaptor having a male thread entry and adapting to female thread same size or higher size
- Reducer having male thread entry and reducing to female thread lower size
- Adaptor Nipple having same size male thread on both end
- Adaptor Coupling have same size female thread on both end

BDPE Series breather/drain plugs are designed to allow moisture emission from Ex e and Ex tb enclosures and to allow air within the enclosure to breathe with the surrounding atmosphere. Drainage channels through the body allow for the passage of moisture through the filter. The device may be screwed into the wall of an enclosure or into a through hole, being secured by a locknut.

Parallel threaded Breather Drains may be fitted with thread seal and screwed into the wall of an enclosure or into a through hole, being secured with a castellated locknut, they will maintain IP66 degree of protection.

Tapered threaded Breather Drain may be fitted with or without thread seal, see below for approved seals. When fitted with thread seal and secured into a through hole, they will maintain IP66 degree of protection.

SCHEDULE:

EU-Type Examination Certificate Number: ETL22ATEX0109X

Explanation on ordering coding and model nomenclature of E1FW / E1FX / E1FU / A2F / CW e / CX e / CU e / IP68 / PX2K / PXSS2K Cable Glands:

"C" Cable Gland Size	Standard Entry Thread "C"				Optional Entry Thread "C"	
	Metric	NPT/BSP	ET (BSC)	PG	Metric	NPT
16	M16x1.5	3/8"	5/8"	PG9	-	-
20s16	M20x1.5	1/2"	3/4"	PG11	M25x1.5	3/4"
20s	M20x1.5	1/2"	3/4"	PG11	M25x1.5	3/4"
20	M20x1.5	1/2"	3/4"	PG13.5	M25x1.5	3/4"
25s	M25x1.5	3/4"	1"	PG16	M32x1.5	1"
25	M25x1.5	3/4"	1"	PG21	M32x1.5	1"
32	M32x1.5	1"	1 1/4"	PG29	M40x1.5	1 1/4"
40	M40x1.5	1 1/4"	1 1/2"	PG36	M50x1.5	1 1/2"
50s	M50x1.5	1 1/2"	2"	PG36	M63x1.5	2"
50	M50x1.5	2"	2"	PG42	M63x1.5	2 1/2"
63s	M63x1.5	2"	2 1/2"	PG48	M75x1.5	2 1/2"
63	M63x1.5	2 1/2"	2 1/2"	-	M75x1.5	3"
75s	M75x1.5	2 1/2"	3"	-	M90x2	3"
75	M75x1.5	3"	3"	-	M90x2	3 1/2"
90	M90x2	3 1/2"	3 1/2"	-	M100x2	4"

PRODUCT CODE FOR ORDERING PURPOSE

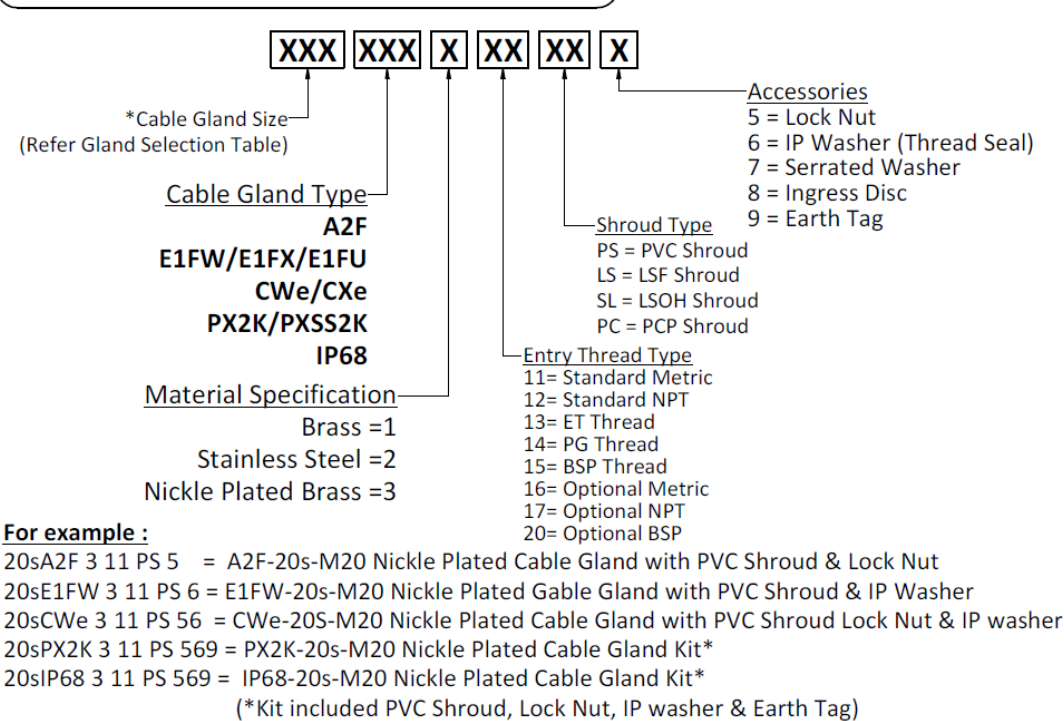

SCHEDULE:

EU-Type Examination Certificate Number: ETL22ATEX0109X

Explanation on ordering coding and model nomenclature of A2F-MH, A2F-MHFC, A2F-MHRF, A2F-MHRM Cable Glands:

*Cable Gland Size	Standard Entry Thread "C"				Optional Entry Thread "C"		Multi Hole Seal Detail	
	Metric	NPT/BSP	ET (BSC)	PG	Metric	NPT/BSP	Seal Hole Cable Ø (X)	Number of Holes
16	M16x1.5	3/8"	3/8"	PG9	M20x1.5	1/2"	1.5	1 to 6
	M16x1.5	3/8"	3/8"	PG9	M20x1.5	1/2"	2.0	1 to 6
20	M20x1.5	1/2"	3/4"	PG16	M25x1.5	3/4"	2.5	1 to 7
	M20x1.5	1/2"	3/4"	PG16	M25x1.5	3/4"	3.0	1 to 7
	M20x1.5	1/2"	3/4"	PG16	M25x1.5	3/4"	3.6	1 to 7
	M20x1.5	1/2"	3/4"	PG16	M25x1.5	3/4"	4.0	1 to 7
25	M25x1.5	3/4"	1"	PG21	M32x1.5	1"	2.5	1 to 7
	M25x1.5	3/4"	1"	PG21	M32x1.5	1"	3.0	1 to 7
	M25x1.5	3/4"	1"	PG21	M32x1.5	1"	3.6	1 to 7
	M25x1.5	3/4"	1"	PG21	M32x1.5	1"	4.0	1 to 7
32	M32x1.5	1"	1 1/4"	PG29	M40x1.5	1 1/4"	2.5	1 to 7
	M32x1.5	1"	1 1/4"	PG29	M40x1.5	1 1/4"	3.0	1 to 7
	M32x1.5	1"	1 1/4"	PG29	M40x1.5	1 1/4"	3.6	1 to 7
	M32x1.5	1"	1 1/4"	PG29	M40x1.5	1 1/4"	4.0	1 to 7

PRODUCT CODE FOR ORDERING PURPOSE For Fig. 1 to 4

Refer Table 1 for Gland Selection

XX XXXX XXXX X XX XX XX X X X

*Cable Gland Size (Refer Gland Selection Table)

Cable Gland Type
A2FMH
A2FMHFC
A2FMHRF
A2FMHRM

Size of Flexible Conduit
A050/A060 etc.....

Material Specification
1= Brass
2= Stainless Steel
3=Nickle Plated Brass

Entry Thread Type
11= Standard Metric
12= Standard NPT
13= ET Thread
14= PG Thread
15= BSP Thread
16= Optional Metric
17= Optional NPT
20= Optional BSP

Conduit Standard Fittings Thread
11= Standard Metric
12= Standard NPT
13= ET Thread
14= PG Thread
15= BSP Thread
16= Optional Metric
17= Optional NPT
20= Optional BSP

Specify Number of holes* Between 1 to 7 (Respectively)

Ordering suffix for Seal
A, B, C, D

Accessories
5 = Lock Nut
6 = IP Washer (Thread Seal)
7 = Serrated Washer
8 = Ingress Disc
9 = Earth Tag

Shroud Type
PS = PVC Shroud
LS = LSF Shroud
SL = LSOH Shroud
PC = PCP Shroud

For example : 20A2FMH 3 11 PS6A7 = A2FMH-20-M20 Nickle Plated Cable Gland with PVC Shroud & IP Washer with Seal A with 7 holes.
: 20A2FMHFC A050 3 11 PS6A7 = A2FMHFC-20-A050-M20 Nickle Plated Cable Gland with PVC Shroud & IP Washer with Seal A with 7 holes.
: 20A2FMHRF 3 11 11 PS569A7 = A2FMHRF-20-M20(M)-M20(F) Nickle Plated Cable Gland Kit* with Seal A with 7 holes.
(*Kit includes PVC Shroud, Lock Nut, IP Washer & Earth Tag)

SCHEDULE:

EU-Type Examination Certificate Number: ETL22ATEX0109X

Explanation on ordering coding and model nomenclature of A2FFF, A2FFFC, A2FFRF, A2FFRM, SS2KGPFF Cable Glands:

*Cable Gland Size	Standard Entry Thread "C"		Optional Entry Thread "C"		Cable Range		No. of Flat Cable used
	Metric	NPT	Metric	NPT	Min	Max	
20s	M20x1.5	½"	M25x1.5	¾"	4x6.2	6.8x11.7	1
20	M20x1.5	½"	M25x1.5	¾"	5.7x8	8.7x13.5	1
25s	M25x1.5	¾"	M32x1.5	1"	4x6.2	6.8x11.7	2
25	M25x1.5	¾"	M32x1.5	1"	5.7x8	8.7x13.5	1
32s	M32x1.5	1"	M40x1.5	1¼"	4x6.2	6.8x11.7	3
32	M32x1.5	1"	M40x1.5	1¼"	5.7x8	8.7x13.5	3

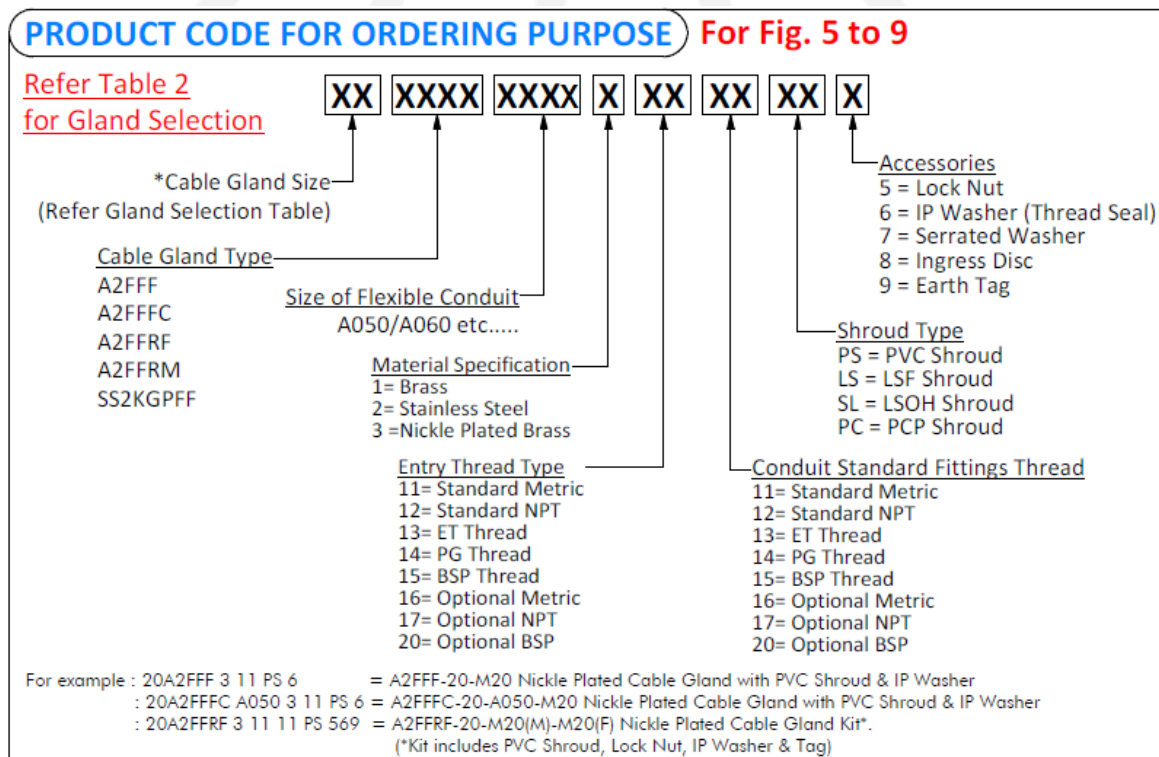

SCHEDULE:

EU-Type Examination Certificate Number: ETL22ATEX0109X

Explanation on ordering coding and model nomenclature of Reducer(R), Adaptor(A), Adaptor Nipple (AN), Adaptor coupling (AC)

Threaded Adaptor and Reducer

Male Metric/NPT/BSP/BSC Entry Size	Female Metric/NPT/BSP/BSC Thread Size									
	M16 3/8", 5/8" ET	M20 1/2", 3/4" ET	M25 3/4", 1" ET	M32 1", 1 1/4" ET	M40 1 1/4", 1 1/2" ET	M50 1 1/2", 2" ET	M63 2", 2 1/2" ET	M75 2 1/2", 3" ET	M90 3", 3 1/2" ET	M100 3 1/2", 4" ET
M16 3/8", 5/8" ET	A	A	A							
M20 1/2", 3/4" ET	R	A	A	A	A					
M25 3/4", 1" ET	R	R	A	A	A	A				
M32 1", 1 1/4" ET	R	R	R	A	A	A	A			
M40 1 1/4", 1 1/2" ET	R	R	R	R	A	A	A	A		
M50 1 1/2", 2" ET			R	R	R	A	A	A		
M63 2", 2 1/2" ET				R	R	R	A	A		
M75 2 1/2", 3" ET						R	R	A	A	
M90 3", 3 1/2" ET							R	R	R	A

Male to Male (Adaptor Nipple) and Female to Female (Adaptor Coupling) Thread Converter

Male/Female Metric/NPT/BSP/ET(BSC) Entry Size	Male/Female Metric/NPT/BSP/ET(BSC) Thread Size								
	M16 3/8", 5/8" ET	M20 1/2", 3/4" ET	M25 3/4", 1" ET	M32 1", 1 1/4" ET	M40 1 1/4", 1 1/2" ET	M50 1 1/2", 2" ET	M63 2", 2 1/2" ET	M75 2 1/2", 3" ET	
M16 3/8", 5/8" ET									
M20 1/2", 3/4" ET									
M25 3/4", 1" ET									
M32 1", 1 1/4" ET									
M40 1 1/4", 1 1/2" ET									
M50 1 1/2", 2" ET									
M63 2", 2 1/2" ET									
M75 2 1/2", 3" ET									

SCHEDULE:

EU-Type Examination Certificate Number: ETL22ATEX0109X

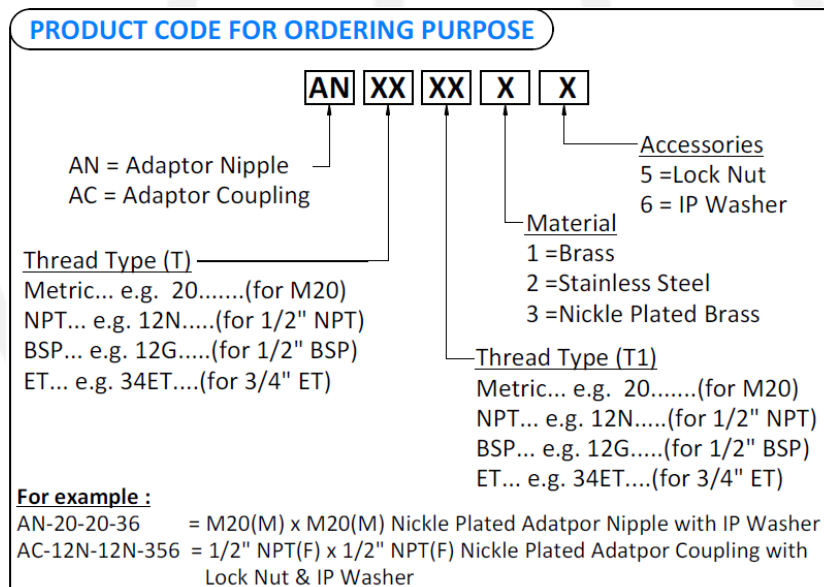
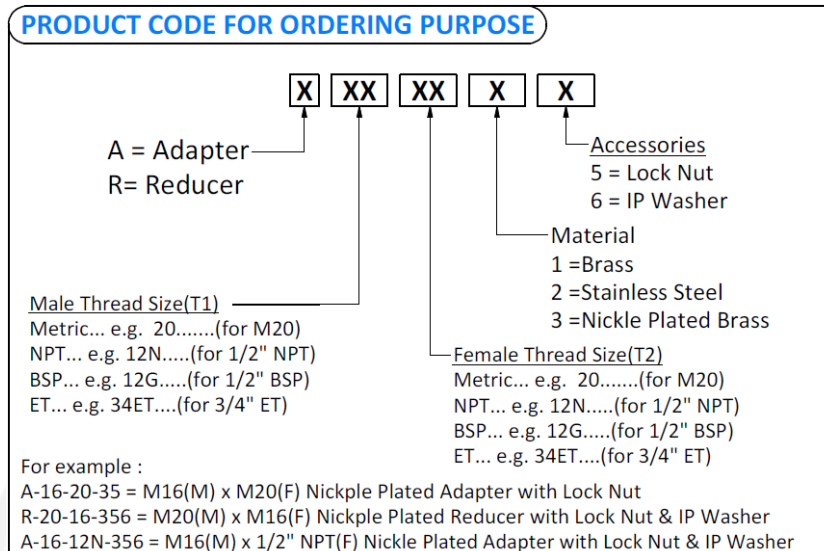

SCHEDULE:

EU-Type Examination Certificate Number: ETL22ATEX0109X

Explanation on ordering coding and model nomenclature of Ex e Breather/drain plug (BDPE)

“*” Cable Gland Size	Standard Entry Thread “C”				Optional Entry Thread “C”	
	Metric	NPT/BSP	ET (BSC)	PG	Metric	NPT
16	M16x1.5	3/8”	5/8”	PG9	-	-
20	M20x1.5	1/2”	3/4”	PG13.5	-	-
25	M25x1.5	3/4”	1”	PG21	M32x1.5	1”

PRODUCT CODE FOR ORDERING PURPOSE

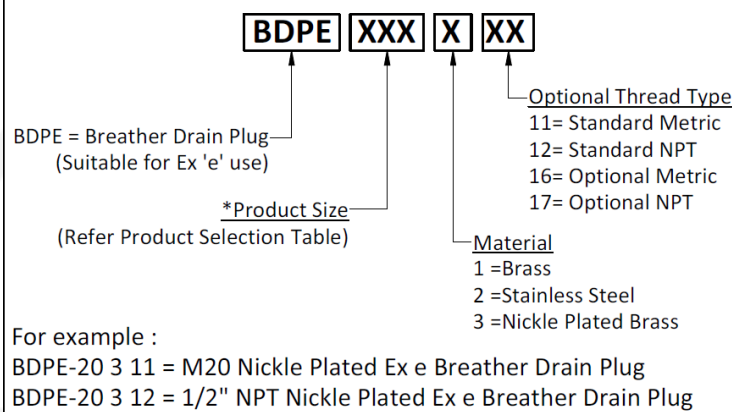

Explanation on coding and model nomenclature of Blanking Elements / Stopping Plug ASP / Hexagonal HSP:

Size	Entry Thread Type			
	Metric	NPT/BSP	ET (BSC)	PG
16	M16x1.5	-	-	-
20	M20x1.5	-	-	-
25	M25x1.5	-	-	-
32	M32x1.5	-	-	-
40	M40x1.5	-	-	-
50	M50x1.5	-	-	-
63	M63x1.5	-	-	-
75	M75x1.5	-	-	-
90	M90x2	-	-	-
100	M100x2	-	-	-
5/8”	-	-	5/8”	-
3/8”	-	3/8”	3/8”	-
1/2”	-	1/2”	1/2”	-
3/4”	-	3/4”	3/4”	-
1”	-	1”	1”	-
1 1/4”	-	1 1/4”	1 1/4”	-
1 1/2”	-	1 1/2”	1 1/2”	-
2”	-	2”	2”	-
2 1/2”	-	2 1/2”	2 1/2”	-
3”	-	3”	3”	-
3 1/2”	-	3 1/2”	3 1/2”	-
7	-	-	-	PG7
9	-	-	-	PG9
11	-	-	-	PG11

SCHEDULE:

EU-Type Examination Certificate Number: ETL22ATEX0109X

13.5				PG13.5
16				PG16
21				PG21
29				PG29
36				PG36
42				PG42
48				PG48

PRODUCT CODE FOR ORDERING PURPOSE

XXX XXX X X

HSP = Hexagonal Stop Plug
ASP = Allen Stop Plug

*Size
(Refer Plug Selection Table)
20.....(for M20)
12N.....(for 1/2" NPT)
12G.....(for 1/2" BSP)
34ET....(for 3/4" ET)
PG7.....(for PG7)

Material
Brass =1
Stainless Steel =2
Nickle Plated Brass =3

Accessories
5 = Lock Nut
6 = IP Washer (Thread Seal)
7 = Serrated Washer

For example:
HSP-20-3= M20 Nickle Plated Hexagonal Stop Plug
HSP-12N-36= 1/2" NPT Nickle Plated Hexagonal Stop Plug with IP Washer
HSP-PG7-356= PG7 Nickle Plated Hexagonal Stop Plug with Nut & IP Washer
ASP-20-35= M20 Nickle Plated Allen Stop Plug with Lock Nut
ASP-12N-35= 1/2" NPT Nickle Plated Allen Stop Plug with Lock Nut
ASP-PG7-356= PG7 Nickle Plated Allen Stop Plug with Lock Nut & IP Washer
ASP-12G-3567= 1/2" BSP Nickle Plated Allen Stop Plug with Lock Nut, IP Washer & Serrated Washer

Ambient and Ingress protection rating:

Product Type	Type of Protection		Ambient Temperature	IP Rating
	Ex d	Ex e		
A2F	✓	✓	-60°C≤Ta≤+125°C	IP67
E1FW/E1FX/E1FU	✓	✓	-60°C≤Ta≤+125°C	IP67
CWe/CXe/CUe	-	✓	-60°C≤Ta≤+125°C	IP67
PX2K	✓	✓	-60°C≤Ta≤+70°C	IP66/67
PXSS2K	✓	✓	-60°C≤Ta≤+70°C	IP66/67
IP68	✓	✓	-60°C≤Ta≤+105°C	IP68
A2FMH/A2FMHFC/A2FMHRF/A2FMHRM/A2FFF/A2FFFC/FA2FFRF/A2FFRM/SS2KGPFF	✓	✓	-60°C≤Ta≤+135°C	IP66/67
Adaptor, Reducer, Adaptor Nipple and Adaptor Coupling	✓	✓	-60°C≤Ta≤+135°C	IP66/67
Hexagon/Allen Stop Plug - Blanking Element	✓	✓	-60°C≤Ta≤+125°C	IP67
Breather/Drain Plug	—	✓	-60°C≤Ta≤+125°C	IP66

SCHEDULE:

EU-Type Examination Certificate Number: ETL22ATEX0109X

12. Report Number

Intertek India Report No. CE-JOB-NDA-22-000031-004 (Intertek UK Certification Report Reference No. G104937979) dated 20th April 2022.

13. Special Conditions of Certification

(a). Special Conditions of Use

Cable Glands:

1. Cable Glands are only suitable for fixed installations.
2. Cables must be effectively clamped from pulling and twisting.
3. Cable Glands shall not be used in enclosure where the temperatures at the point of entry / mounting are outside the range of ambient temperatures as detailed in general description.
4. The glands should only be used with substantially round cables and tightened to the rated torque with torque wrenches.
5. Install in accordance with requirements of EN60079-14.
6. The cable glands are provided with a sealing ring with an axial sealing height of at least 5 mm. With reference to the clearance groove, the end-user should ensure that at least five complete turns of the connector thread are made. In order to guarantee a screw depth of 8 mm, the enclosure should have a wall thickness of min. 10 mm; if <10 mm, then if necessary, use a washer when cable entries are attached to the pressure-resistant enclosure.
7. In the case of NPT connecting threads, the end-user must ensure that the necessary IP protection is guaranteed; this can be done using a suitable thread sealing agent.
8. Installation should not be carried out under live conditions.

Blanking Elements / Stop Plug:

1. The Blanking elements must not be used with a thread adaptor / reducer in flameproof applications.
2. Its user's responsibility to ensure the appropriate ingress protection level on the interfaces between these devices and the associated enclosure.
3. When the stopping plugs are used for increased safety or dust protection and no thread seal is fitted the user shall ensure enclosure and stopping plug interface are suitably sealed, in accordance with EN 60079-14, to maintain the ingress protection rating of the associated enclosure and protection concept.
4. When fitted in threaded holes the sealing face of the enclosure shall be smooth, the threaded hole shall be perpendicular to the wall of the enclosure and shall be a medium fit thread.
5. When the stopping plug is fitted in plain holes, the sealing face of the enclosure shall be smooth and at right angles to the enclosure face where the hole is in excess of 15mm diameter in enclosures consideration must be given to possible draw angle (taper) on the enclosure wall and the hole shall be no larger than 0.3 to 0.5mm above the major diameter of the male thread on the stopping plug.
6. The stopping plug is secured using a suitable locknut inside the enclosure for plain holes in increased safety enclosures.
7. These stopping plugs can be used in clearance holes or tapped entries on increased safety or flameproof enclosures as appropriate.

SCHEDULE:

EU-Type Examination Certificate Number: ETL22ATEX0109X

Adapter, Reducers & Nipples:

1. For Flameproof Ex “db” applications, only one adapter or reducer shall be used per cable entry.
2. The adaptors or reducers when used in flameproof applications must not be closed with a flameproof stopping plug.
3. Its user’s responsibility to ensure the appropriate ingress protection level on the interfaces between these devices and the associated enclosure.
4. When the adaptors and reducers are used for increased safety or dust protection with no thread seal fitted the interface between the enclosure and the male thread and the female thread of the adaptor or reducer are to be suitably sealed (in accordance with EN 60079-14) to maintain the ingress protection rating of the associated enclosure.
5. When the adaptors or reducers are used for increased safety or dust protection in threaded hole and the thread seal is fitted the entry thread in the enclosure must be at right angles to the enclosure wall, the female thread of the adaptor or reducer are to be suitably sealed, in accordance with EN 60079-14, to maintain the ingress protection rating of the associated enclosure.
6. When the adaptors or reducers are used for increased safety or dust protection in a plain hole, the hole in the enclosure must be no greater than 0.7 mm greater than the male thread and the adaptor or reducer must be secured with a locknut the female thread of the adaptor or reducer are to be suitably sealed, in accordance with EN 60079-14, to maintain the ingress protection rating of the associated enclosure.
7. In the case of NPT connecting threads, the end-user must ensure that the necessary IP protection is guaranteed; this can be done using a suitable thread sealing agent.

Breather / Drain Plugs

1. The breather drain plugs shall be used with the supplied sealing washers and the installer shall ensure that the surface of the enclosure against which the sealing gasket seals are in good condition.
2. The breather/drains are only suitable for bottom entry applications within associated Ex eb and Ex tb enclosures.

(b). Conditions of Manufacture - Routine Tests

None.

14. Essential Health and Safety Requirements (EHSRs)

The relevant Essential Health and Safety Requirements (EHSRs) have been identified and assessed in Intertek India Report No. CE-JOB-NDA-22-000031-004 (Intertek UK Certification Report Reference No. G104937979) dated 20th April 2022.

SCHEDULE:

EU-Type Examination Certificate Number: ETL22ATEX0109X

15. Drawings and Documents

Title:	Drawing No.:	Rev. Level:	Date:
Cable Glands			
*E1F Ex Cable Gland	Ex-CE1F	1	12/01/2022
*A2F Ex Cable Gland	Ex-CA2F	1	12/01/2022
*CW Ex Cable Gland	Ex-CCW	1	12/01/2022
*A2FMH/A2FFF/SS2KGPFF Cable Gland 2 Sheets	Ex-A2FFF/RC	0	12/01/2022
*Explosion Proof Compound Barrier Cable Gland 2 Sheets	Ex-CBC	0	12/01/2022
*IP68 Cable Gland	Ex-IP68	0	12/01/2022
*Adapter 5 Sheets	Ex-A#	0	12/01/2022
*Reducer 5 Sheets	Ex-R#	0	12/01/2022
*Adaptor Nipple 2 Sheets	Ex-AN#	0	12/01/2022
*Adaptor Coupling 2 Sheets	Ex-AC#	0	12/01/2022
Stop Plug / Blanking Elements			
*Hexagonal Stop Plug/Blanking Element	Ex-CHSP	1	12/01/2022
*Allen Stop Plug/Blanking Element	Ex-CASP	1	12/01/2022
*Breather Drain Plug for Ex e applications	Ex-BDPE-#	0	12/01/2022
*Installation Manual for A2F Cable Gland	IM / Cable Gland A2F series	1	12.01.2022
*Installation Manual for A2FFF Cable Gland	IM / Cable Gland A2FFF series	0	12.01.2022
*Installation Manual for A2FFFC Cable Gland	IM / Cable Gland A2FFCF series	0	12.01.2022
*Installation Manual for A2FFRF Cable Gland	IM / Cable Gland A2FFRF series	0	12.01.2022
*Installation Manual for A2FFRM Cable Gland	IM / Cable Gland A2FFRM series	0	12.01.2022
*Installation Manual for A2FMH Cable Gland	IM / Cable Gland A2FMH series	0	12.01.2022
*Installation Manual for A2FMHFC Cable Gland	IM / Cable Gland A2FMHFC series	0	12.01.2022
*Installation Manual for A2FMHRF Cable Gland	IM / Cable Gland A2FMHRF series	0	12.01.2022
*Installation Manual for A2FMHRM Cable Gland	IM / Cable Gland A2FMHRM series	0	12.01.2022
*Installation Manual for Adaptor & Reducer	IM / A-R-AN-AC Series	0	12.01.2022
*Installation Manual for Stopping Plug/Blanking Element	IM / Blanking Elements	01	12.01.2022

SCHEDULE:

EU-Type Examination Certificate Number: ETL22ATEX0109X

*Installation Manual for Compound Barrier PX2K Cable Gland	IM / Cable Gland Compound Barrier PX2K Series	0	12.01.2022
*Installation Manual for Compound Barrier PXSS2K Cable Gland	IM / Cable Gland Compound Barrier PXSS2K Series	0	12.01.2022
*Installation Manual for Compound Barrier SS2KGP-FF Cable Gland	IM / Cable Gland Compound Barrier SS2KGP-FF Series	0	12.01.2022
*Installation Manual for CW Cable Gland	IM / Cable Gland CW series	01	12.01.2022
*Installation Manual for E1F Cable Gland	IM / Cable Gland E1F series	01	12.01.2022
*Installation Manual for IP68 Cable Gland	IM / Cable Gland IP68 series	0	12.01.2022
*Installation Manual for Breather Drain Plug	IM / BDPE series	0	12.01.2022